

BALDOR® • RELIANCE 

Product Information Packet

XEFRPM32504

50HP,1800,460V,HL326T,TEFC,F1

Part Detail							
Revision:	E	Status:	PRD/A	Change #:		Proprietary:	No
Type:	AC	Elec. Spec:	LS7021A	CD Diagram:	422927-001	Mfg Plant:	
Mech. Spec:		Layout:	619699-001	Poles:	04	Created Date:	05-06-2016
Base:		Eff. Date:	04-23-2019	Leads:			

Specs			
Catalog Number:	XEFRPM32504		
Enclosure:	TEFC		
Frame:	HL326T		
Frame Material:	Exposed Laminations		
Output @ Frequency:	50.000 HP @ 60 HZ		
Synchronous Speed @ Frequency:	1800 RPM @ 60 HZ		
Voltage @ Frequency:	460.0 V @ 60 HZ		
Agency Approvals:	CCSA US		
Auxillary Box:	No Auxillary Box		
Base Indicator:	Rigid		
Bearing Grease Type:	Polyrex EM (-20F +300F)		
Constant Torque Speed Range:	1-60		
Current @ Voltage:	49.000 A @ 460.0 V		
Duty Rating:	CONT		
Feedback Device:	NO FEEDBACK		
Frame Prefix:	HL		
Heater Indicator:	No Heater		
Insulation Class:	H		

IP Rating:	IP54		
KVA Code:	F		
Mounting Arrangement:	F1		
Product Family:	Fan		
Pulley End Bearing Type:	Ball		
Pulley Face Code:	Other		
Shaft Ground Indicator:	No Shaft Grounding		
Shaft Rotation:	Reversible		
Motor Standards:	NEMA		
Thermal Device - Bearing:	None		
Thermal Device - Winding:	None		

Nameplate 000613007QF												
	DUTY	HP	RPM	AMPS	VOLTS	HZ						
	CONT	50	1800	49	460	60						
CAT.NO.	XEFRPM32504		SPEC. NO.		H32-A000-0001							
SER.NO.			FRAME SIZE		HL326T		TYPE PSM					
AMB.	40	S.F.	1.15	ENCL.	TEFC	PH	3	DESIGN	B	CODE	F	
NEMA NOM. EFF	96.6		GUARANTEED EFFICIENCY		95.9		POWER FACTOR		97.2		INSUL. CLASS	H
D.E. BRG.	65BC03J30X		O.D.E. BRG.		50BC03J30X							
VPWM INVERTER DUTY @1.0SF	CHP HZ	60-90		CT HZ	1-60		VT HZ	0-60				
	X/T											

Nameplate 000692000VY		
IS <input type="text"/>	MEAS OPEN CIRCUIT VOLTAGE VOLTS AT <input type="text"/>	RPM.
EXCEED L.R. <input type="text"/>	MTR PH CURRENT SHOULD NOT	AMPS RMS PEAK TO
AVOID DEMAGNETIZATION		

Parts List		
Part Number	Description	Quantity
WS311990	WS H32-A000-0001	1.000 EA
RA308215	RA H32-A000-0001	1.000 EA
000692000VD	LABEL WARNING	1.000 EA
000692000FP	NP, WARNING LIFT INSTRUCTIONS	1.000 EA
418057747A	METAL FASTENER	8.000 EA
000613007QF	NP,RPM AC - XE WITH CERTIFIED LOGO	1.000 EA
000613006ABP	RPM-XE,EXTREME EFFICIENCY,UL LISTED	1.000 EA
000692000VY	PERMANENT MAGNET MOTOR NAMEPLATE	1.000 EA
422927001	C/D LABEL	1.000 EA
004824007AB	PAINT,XT	0.100 EA
810103004AAC	BRKT,ODE,LSPM250 (FL250)	1.000 EA
810103003AAA	BRKT,DE,LSPM250 (FL250)	1.000 EA
HA4054	SHORT T-DRAIN FITTING, .125" N.P.T.	1.000 EA
HA4054	SHORT T-DRAIN FITTING, .125" N.P.T.	1.000 EA
004824015A	GREASE POLYREX EM	0.200 LB
415045002G	SLGR	1.000 EA
415045002E	SLGR	1.000 EA
400638001H	SPRING WASHER (Customer number 43699)	1.000 EA
036610010AB	MHSLW M10 PLATED	4.000 EA
418150003A	GREASE FITTING CAP	2.000 EA
035000001A	ALFTG 1/8" 1610-BL	1.000 EA
035000001A	ALFTG 1/8" 1610-BL	1.000 EA
036100080KA	M10-1.50X 80MM HXSOCHDCS	3.000 EA
036100080KA	M10-1.50X 80MM HXSOCHDCS	3.000 EA

Parts List (continued)		
Part Number	Description	Quantity
036140001C	EYEBOLT - 400	2.000 EA
034693001AB	PPLG - G508- use 034692001AB	1.000 EA
034693001AB	PPLG - G508- use 034692001AB	1.000 EA
036500010AB	METRIC NUT M10-1.5PLTD400	4.000 EA
036500010AB	METRIC NUT M10-1.5PLTD400	4.000 EA
609830005M	TBOLT METRIC RP609830-	4.000 EA
415000103A	T/LUG #14AWG-#4AWG W/HOLE FOR .250 BOLT	1.000 EA
415072001B	CLAMP	1.000 EA
417733004T	GASKET CONDUIT BOX	2.000 EA
034180012FA	KEY 3/8X3/8X1-1/2 L - 360	1.000 EA
078548001T	FAN 250	1.000 EA
708534505A	BLOWER SHROUD,HL320	1.000 EA
036000012HB	HHCS M6X12MM LONG PLATED	4.000 EA
418018074A	GROUND LABEL G100 METRIC 160 D.C.	1.000 EA
406673002AE	2" CAP PLUG	1.000 EA
036620008AB	M6 METRIC EXT LOCKWASHER	1.000 EA
418010012J	CONDUIT BOX SPACER	1.000 EA
036601008AB	M6 FLAT WASHER	4.000 EA
075460062B	+C/B - 280	1.000 EA
075461011A	+CBOX CVR BLKT - 280	1.000 EA
065591000C	GASK 250-280	1.000 EA
032018008AK	HHCS 1/4-20X1 PLATED	2.000 EA
036000050HB	MHHCS M6X50MM PLATED	4.000 EA
034180032GA	KEY 1/2X1/2X4 L	1.000 EA

004824007K	SPECIAL PAINT	0.100 EA
------------	---------------	----------

S. O.	FRAME	HP	TYPE	PHASE	HERTZ	RPM
--	HL326T	50	PSM	3	60	1800
VOLTS	AMPS	DUTY	AMB°C	INSUL	S. F.	NEMA DESIGN
460	50.0	CONT	40	H	1.15	B
CODE LETTER	ENCL	ROTOR INERTIA (lb-ft ²)		STATOR RES. @ 25°C OHMS (BETWEEN LINES)		
F	TEFC	3.89		.1878		TYPICAL DATA
PERFORMANCE						
LOAD	HP	AMPERES	RPM	POWER FACTOR %	EFFICIENCY %	
NO LOAD	0	19.8	1800	3.80	N/A	
1/4	12.5	16.5	1800	75.5	93.9	
2/4	24.9	25.7	1800	94.8	95.9	
3/4	37.4	37.5	1800	97.3	96.3	
4/4	49.9	50.0	1800	97.2	96.2	
5/4	62.4	63.5	1800	96.2	95.8	
SPEED TORQUE						
		RPM	TORQUE (% FULL LOAD)	TORQUE (lb-ft)	AMPERES	
LOCKED ROTOR		0	166	242.2	340.5	
PULL OUT		1800	208	302.5	132.4	
FULL LOAD		1800	100	145.7	50.0	
<p>THIS IS A PERMANENT MAGNET MOTOR</p> <p>GENERATED OPEN CIRCUIT LINE-LINE VOLTAGE at 25°C = 20.4 VOLTS PER 100 RPM</p> <p>REMARKS:</p>						
		DR. BY CAD CK. BY RBM APP. BY RBM DATE 05/25/2016		LSPM MOTOR PERFORMANCE DATA IS7021A ISSUE DATE 05/25/2016		
A MEMBER OF THE ABB GROUP						

S. O.	--	HERTZ	60	AMB°C	40	CODE LETTER	F
FRAME	HL326T	RPM	1800	INSUL.	H	WK ² (lb-ft ²)	3.89
HP	50	VOLTS	460	S.F.	1.15	NEMA DESIGN	B
TYPE	PSM	AMPS	50.0	ENCL.	TEFC	STATOR RES. @ 25°C	.1878
PHASE	3	DUTY	CONT			OHMS (BETWEEN LINES)	

**Amps & Torque vs. RPM
During Acceleration**

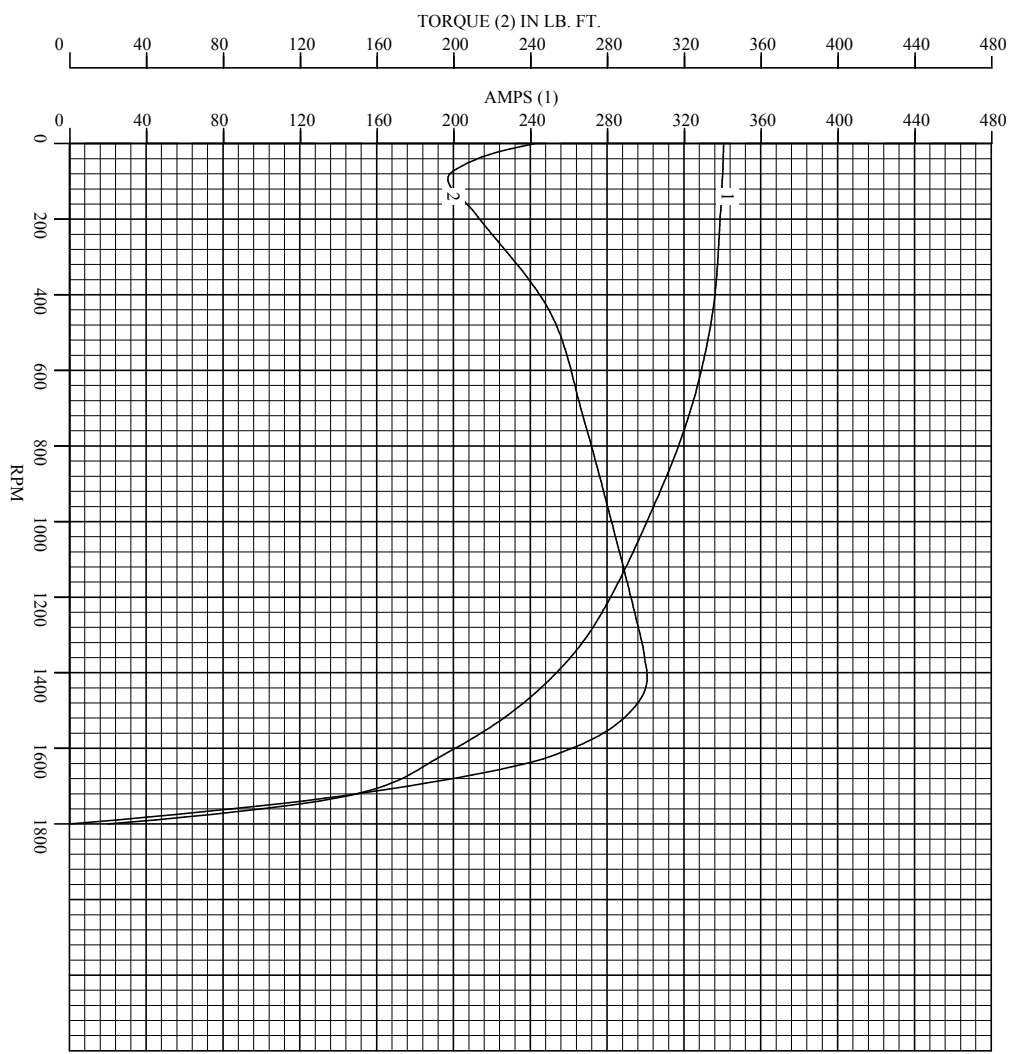

Typical Data

BALDOR
A MEMBER OF THE ABB GROUP

DR. BY CAD
CR. BY RHM
APP. BY RHM
DATE 05/25/2016

**ISPM MOTOR
PERFORMANCE
CURVES**

ISSUE DATE **L57021A**
05/25/2016

S. O.	--	HERTZ	60	AMB°C	40	CODE LETTER	F
FRAME	HL326T	RPM	1800	INSUL	H	WK ² (lb-ft ²)	3.89
HP	50	VOLTS	460	S.F.	1.15	NEMA DESIGN	B
TYPE	PSM	AMPS	50.0	ENCL	TEFC	STATOR RES. @ 25°C	.1878
PHASE	3	DUTY	CONT			OHMS (BETWEEN LINES)	

Performance Data vs. HP
At Synchronous Speed

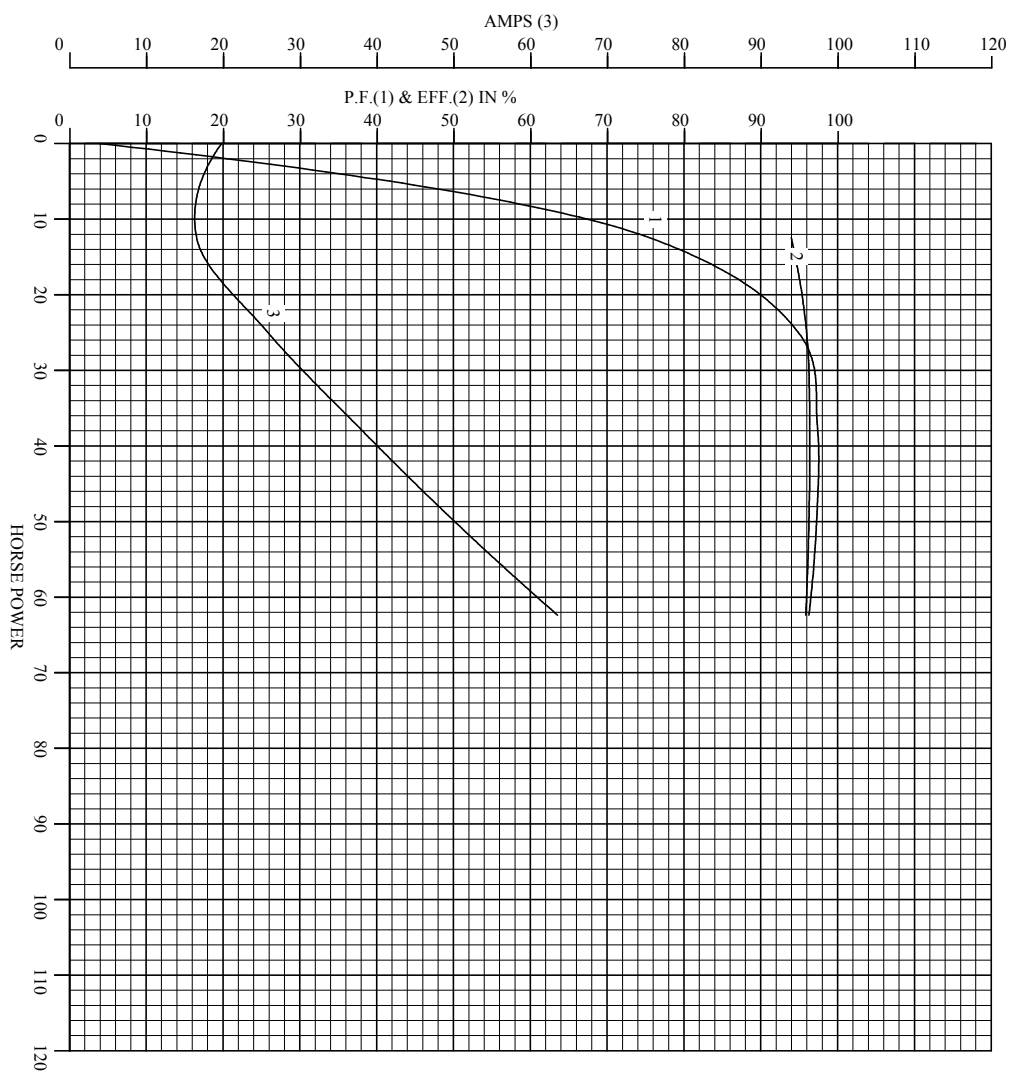

TYPICAL DATA

BALDOR
A MEMBER OF THE ABB GROUP

DR. BY	CAD
CR. BY	RHM
APP. BY	RHM
DATE	05/25/2016

ISPM MOTOR PERFORMANCE CURVES ISSUE DATE L57021A 05/25/2016

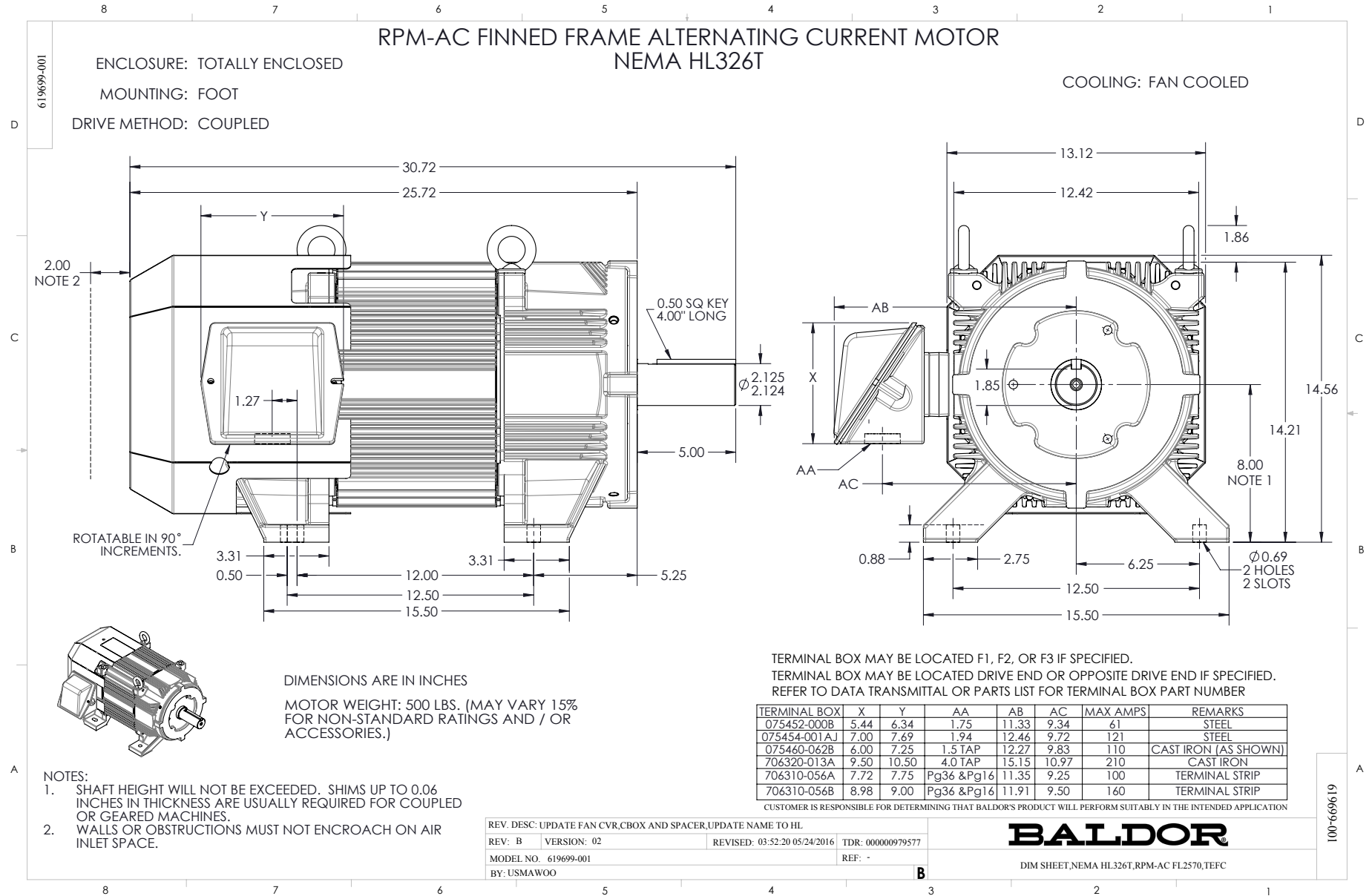

422927-001

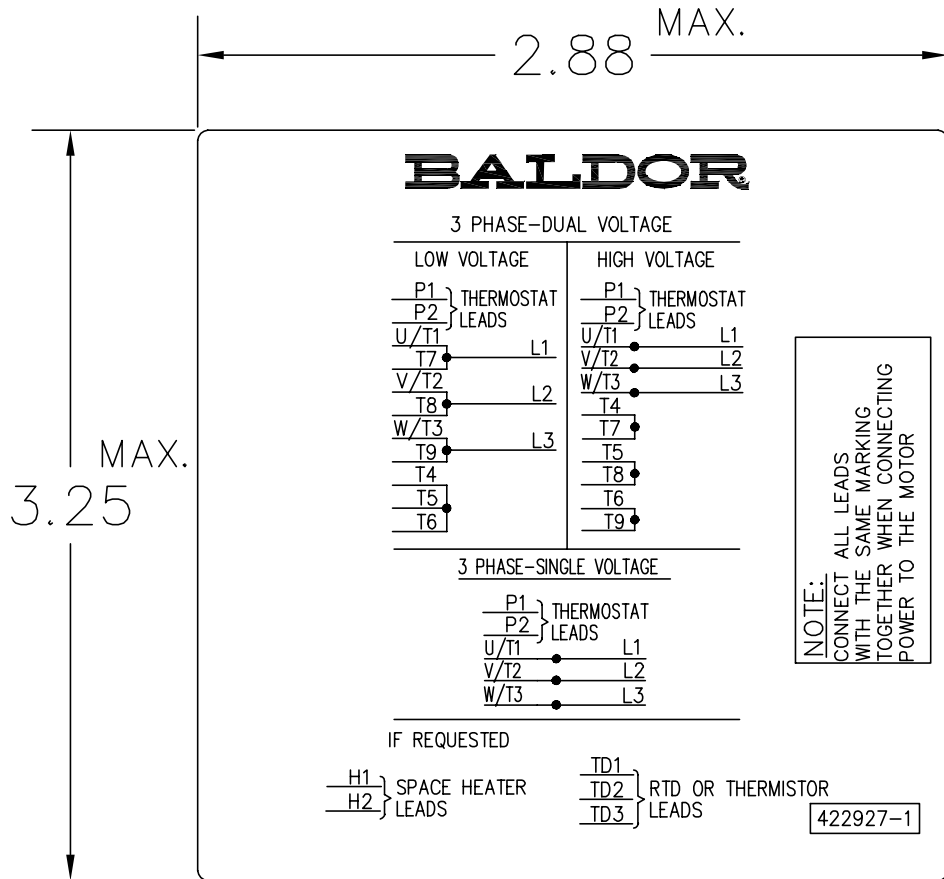

NOTE:
DATA TO BE SIZED
SO THAT IT FITS INTO
MATERIAL DECAL
DIMENSIONS. MAKE
LETTERS & NUMBERS
AS LARGE AS POSSIBLE.

MATERIAL: CERAMATIC DGF-P4
PERMA GRIP ADHESIVE

ALL LETTERS, NUMBERS
AND LINES TO BE BLACK
ON WHITE BACKGROUND.

422927-001

REV. DESC: CHANGE BACKGROUND COLOR FROM GOLD TO WHITE		
REV. LTR: B	VERSION: 02	TDR: 000000788708
FILE: \RGG\00000\203	REVISED: 08:09:29 03/04/2013	
MTL: -	BY: RGGWT	

BALDOR

EXTERNAL CONNECTION LABEL

SH 1 of 1

Marketing maintained PDF of MN442:

<http://www.baldor.com/mvc/DownloadCenter/Files/mn442>